

Kilovac PD10 Make & Break Load Switching

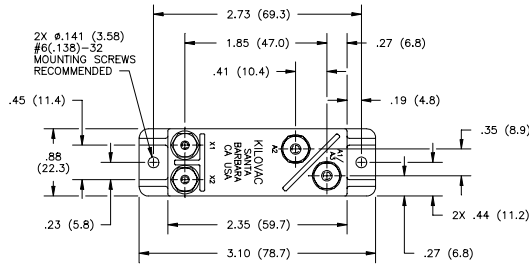

Features:

- Excellent for control applications
- PCB and panel mountings
- Rugged design for the most demanding applications, including seismic shock
- Small size and weight
- Low power consumption
- No heat sinks required
- Vacuum-sealed; can operate in explosive and harsh environments
- 2000V isolation across open contacts
- Meets requirements of SAE ARD 50031
- Vacuum dielectric for power switching

Panel Mount Version shown above is applicable to both PD5 and PD10. For PD10, the two power terminals are .064" (1.63) diameter. Refer to PD5 for PCB Mount Dimensions.

CONTACT RATINGS*

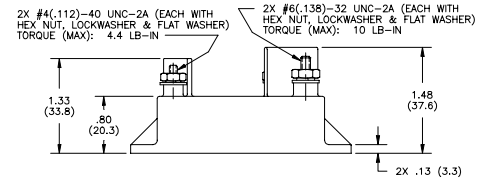
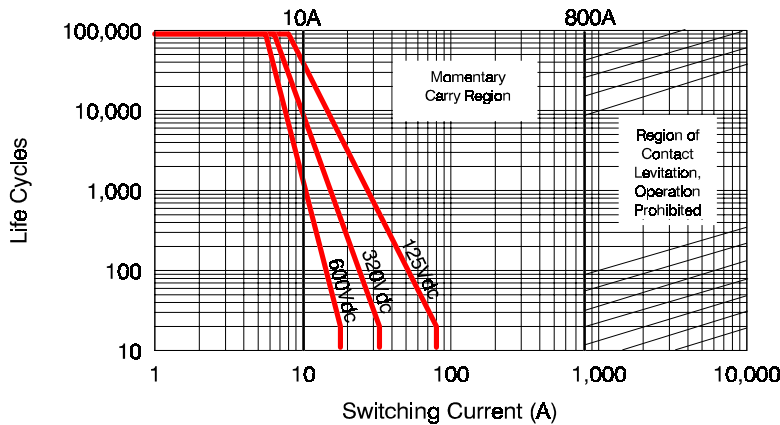

ESTIMATED SHORT TERM CURRENT

Duration(Sec.)	Current (Amps)
100	140
60	150
10	200
1	600

* Based on extrapolated data. Since each application is unique, user is encouraged to verify rating in actual application. The load terminals should always be connected as follows: Common Contact (A2) positive; Other Contact negative.

PRODUCT SPECIFICATIONS

Part Number	UNIT	PD10A	PD10B	PD10P
Contact Arrangement		SPST-NO	SPST-NC	SPST-Latching
Contact Form		A**	B**	P**
Rated Resistive Load @ 320 Vdc	A	10	10	30
Continuous Current Carry, Max. @ 85°C	A	15	15	10
Overload @ 320 Vdc (make/break)	A	20	20	20
Life, (Mechanical/Rated Load)	cycles	500k/10k	500k/10k	7,000
Contact Resistance, Max., end of life	ohms	0.010	0.010	0.030
Dielectric at Sea Level				
Power Terminals to Coil & all other points	Vrms	1,800	1,800	2,000
Shock, 11ms 1/2 Sine (peak)	G's Peak	25	25	25
Vibration, Sinusoidal (55-2000 Hz, peak)	G's	5	5	5
Operating Ambient Temperature Range	°C	-40 to +85	-40 to +85	-35 to +65
Operate Time, Max., including Bounce @ 25°C	ms	10	10	6
Release Time, Max., including Bounce @ 25°C	ms	10	10	6
Insulation Resistance @ 500 Vdc, Min.				
Initial/ End of Life	Mohm	100/50	100/50	100/50
Weight, Nominal	g (lb)	71(.156)	71(.156)	71(.156)

** Contact factory for the availability of other contact forms

COIL DATA

Nominal, Volts dc	12	24	125	Unit
Maximum Coil Voltage	14	28	130	Vdc
Pickup, Max. @ 85°C	8	16	80	
Hold, Min. @ 85°C	3.3	10	33	
Drop-Out, Min. @ -40°C	.5	1	5	
Coil Resistance (±10%)	70	290	4700	Ohms

Ratings listed are for 25°C, sea level conditions

PART NUMBER SELECTION

Sample Part No. PD10

Contact Form
A = SPST-NO
B = SPST-NC
P = SPST-Latching

Coil Voltage
2 = 12 Vdc, PCB Version
3 = 24 Vdc, PCB Version
5 = 125 Vdc, PCB Version
A = 12 Vdc, Panel Mount Version
B = 24 Vdc, Panel Mount Version
C = 125 Vdc, Panel Mount Version

Power Terminals
3 = PCB Solder Connection
5 = Stud Terminal, Panel Mount

Mounting
5 = PCB Mount
7 = Panel Mount