

KILOVAC EV200 - 200 Amps ("Czonka III")

Make & Break Load Switching

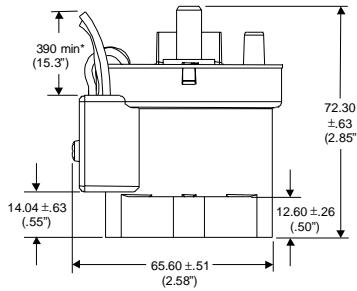

*Lead length is 244 mm (9.6") until stock is depleted. Length is being increased to 390 mm (15.3") by Feb. 2001, or sooner. Contact factory if longer lengths are needed prior to Feb. 2001.

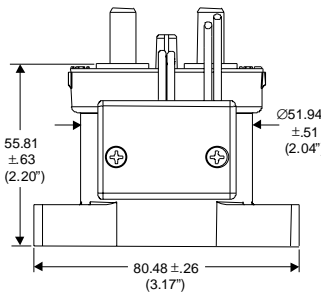
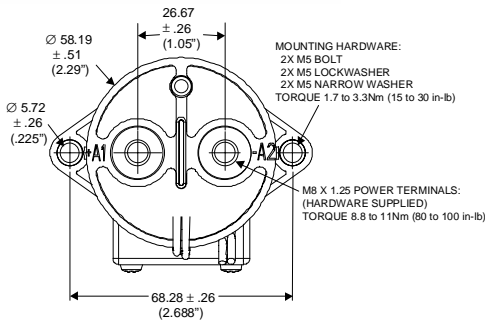

Features:

- **Low Cost** - lowest price sealed relay in the industry with its contact rating
- **Highest contact rating for its size** - 200 A carry, 2,000 A interrupt at 320 Vdc.
- **Optional Auxillary Contact** - Easy monitoring of power contact position
- **Built-In Coil Economizer** - Only 1.7 W hold power @ 12 Vdc making it ideal for battery powered systems. Models are available requiring external coil economizer for large volume applications
- **Hermetically Sealed** - Intrinsically safe, operates in explosive & harsh environments like salt, moisture, dust with no oxidation or contamination of coils or contacts providing stable contact resistance over years of use, including long periods of non-operation
- **Small & Lightweight** - smallest sealed relay in the industry with its current rating
- **No Coil Back EMF** - Built-in coil economizer limits back EMF to zero volts
- **Versatile Coil Connection** - Flying leads to accommodate your connector
- **Multiple use Applications** - Ideal for battery switching & back-up, DC voltage power control, circuit protection and safety

PRODUCT SPECIFICATIONS		
Part Number	Units	EV200
Contact Arrangement : Power Contacts		SPST-NO
Aux. Contacts		SPST-NO
Contact Form		A
Continuous Current Carry, Max. (2/0 Cable Req'd) ^{1/}	A	200
100 Seconds	A	325 ^{4/}
10 Seconds	A	500 ^{4/}
Make & Break Current (various voltages) ^{1/}	A	see back sheet
Break Current @ 320 Vdc ^{1/}	A	2,000, 1 cyc ^{5/}
Aux. Contact Current, max @ 30 Vdc/125 Vac	A	2/3
(no lower than 8V @ 100mA)		
Aux. Contact Resistance, max. 30 Vdc/125 Vac	A	.417/.150
Load Life	cycles	see back sheet
Mechanical Life	cycles	1million
Contact Resistance, Max. (@200A)	mohms	.4
Contact Resistance, Typ. (@200A)	mohms	.1 - .3
Operate Time, 25° C		
Close (includes bounce) Typ.	ms	15
Bounce (after close only), Max.	ms	7
Release Time (includes arcing), Max. @ 2,000A	ms	12
Insulation Resistance @ 500 Vdc, Min.	Mohms	100 ^{3/}
Dielectric at Sea Level (leakage < 1mA)	Vrms	2,200
Shock, 11 ms 1/2 Sine (peak), operating	G's peak	20
Vibration, Sinusoidal (80-2000 Hz, peak)	G's	20
Operating Ambient Temperature Range	°C	-40 to +85
Weight, Nominal	pound (kg)	.95 (.43)

EV200 COIL DATA				
Voltage (will operate)	9 to 36	32 to 95	48 to 95	Vdc
Voltage (max.)	36	95	95	Vdc
Pickup (close), max.	9.0	32	48	Vdc
Hold, Min.	7.0	21	33	Vdc
Dropout (open), min.	6.0	18	27	Vdc
Inrush, max.	3.8	1.3	.7	A
Holding, avg.	.13@12V, .07@24V	.03@48V	.02@72V	A
Inrush Time, max.	130	130	130	ms

PART NUMBER SELECTION						
Sample Part No.	EV200	A	A	A	N	A
Model	EV200					
Form						
A = Normally Open H = Normally Open with Aux.						
Coil Voltage						
A = 9 to 36 D = 32 to 95 J = 48 to 95						
Coil Wire Length						
A = 244 mm (9.6") 390 mm (15.3") after Jan 2001						
Coil Terminal Connector						
N = No Connector						
Mounting & Power Terminals						
A = Bottom Mount & Male 10mm x 8 Terminals						

^{1/} Main Power Contacts
^{2/} Refer to qualification test plan on next page for actual mix of pre-charge and break currents used on each cycle.
^{3/} 50 at end of life
^{4/} Estimated
^{5/} Does not meet dielectric & IR after test

Estimated Make & Break Power Switching Ratings

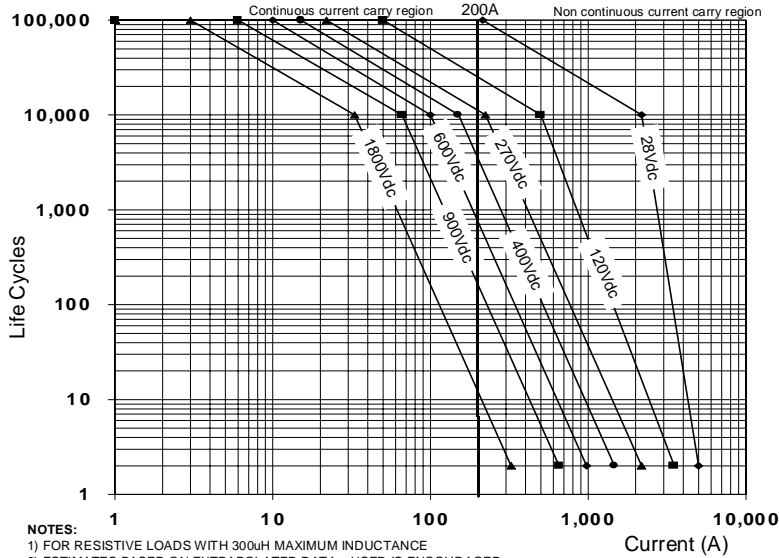

- NOTES:**
- 1) FOR RESISTIVE LOADS WITH 300uH MAXIMUM INDUCTANCE
 - 2) ESTIMATES BASED ON EXTRAPOLATED DATA. USER IS ENCOURAGED TO VERIFY RATING IN ACTUAL APPLICATION
 - 3) END OF LIFE WHEN DIELECTRIC STRENGTH BETWEEN TERMINALS FALLS BELOW 50MΩ @ 500VDC
 - 4) THE MAXIMUM CONTACT MAKE AND BREAK POWER IS ESTIMATED AT 208KW. BREAK ONLY ABOVE 208KW TO AVOID CONTACT WELDING

EV Electrical Load Life Ratings

Make/Break Life Capacitive & Resistive Loads at 320 Vdc (1) (2)		
@90% capacitive pre-charge (make only) see chart below	Cycles	50,000
@80% capacitive pre-charge (make only) see chart below	Cycles	50
@200 A make/break (2 consecutive, reverse polarity) (1)	Cycles	12
2,000 A (break only) (1)	Cycles	1*
Mechanical Life	Cycles	100,000

- (1) Resistive load includes inductance L = 25 uH. Load @ 2500 A tested @ 200 uH.
 (2) Life based on projected Weibull Life with 95% Reliability
 * Does not meet dielectric & IR after test.

