

## 1000 Series

### Features

- Measures airflow directly
- Ultra-sensitive to low velocity
- All solid-state
- Cost-effective
- Easy to use
- Choice of outputs, including 0-10V, 4-20mA
- Access to tight locations
- Temperature readings available



Plastic Case with Panel Mount

Metal Case with DB9 Connector

## Direct Linear Airflow Measurement

The Cambridge AccuSense AVS-1000 Series are embedded, thermistor-based sensors, developed to provide direct, continuous measurements of ultra low air velocity. The AVS-1000 Series feature velocity ranges as low as 0-0.5 m/s (0-100 fpm); the highest velocity range is 0-5 m/s (0-1000 fpm). Users can also specify custom ranges, to fit the particular needs of their own applications. The specially designed, small sensors allow easy access to obtain measurements even in remote and tight locations.

Directly obtaining airflow measurements greatly increases monitoring accuracy and efficiency. Traditional methods using differential pressure result in extremely low readings which are difficult to measure economically and accurately.

AVS-1000 Series sensors are available in two versions, bi-directional or non-directional. The non-directional sensor measures the maximum velocity passing the sensor. The bi-directional sensor gives a positive or negative reading to indicate the direction of the airflow.

An all solid-state construction ensures durability and stable operation, while the processing electronics inside the AVS Series perform temperature compensation and linearization of output. Applications for this new technology include airflow monitoring in sensitive environments such as isolation rooms, cleanrooms, fume hoods and biological safety cabinets, as well as leak detection and gas metering for duct work, HVAC and process control.

Supply voltage options include 12V or 24 VDC, with outputs of 0-10V or 4-20mA. Packaging options include plastic or metal case with pins or DB9 connections. A new metal case with an aluminum wand is now available, called the Universal package.

## Typical Applications

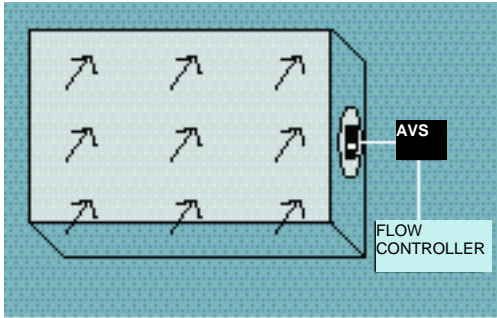

**Application:**  
Fume Hoods

The AVS can be mounted into the side wall or incoming duct to measure and control face velocities of fume hoods.

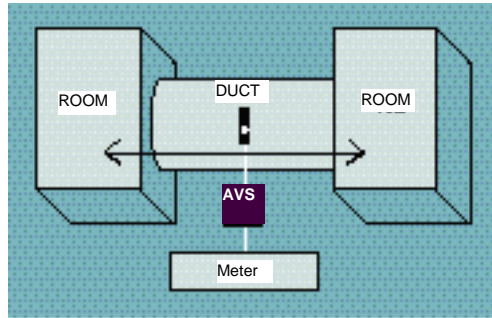

**Application:**  
Isolation Rooms

A bi-directional AVS is optimal for monitoring isolation rooms and operating rooms where air velocity and direction are critical.

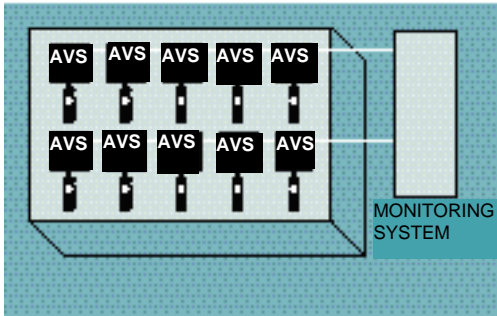

**Application:**  
Cleanrooms

Mount several AVS sensors by inlets, outlets, filters and other critical areas. Transmit the data over long distances for continuous monitoring of airflow.

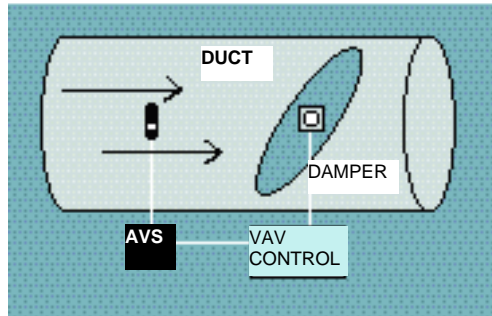

**Application:**  
Air Ducts

Use the AVS as a replacement for cumbersome conversion of pressure measurements to an airflow reading.

## Dimensions

Plastic Case

Metal Case

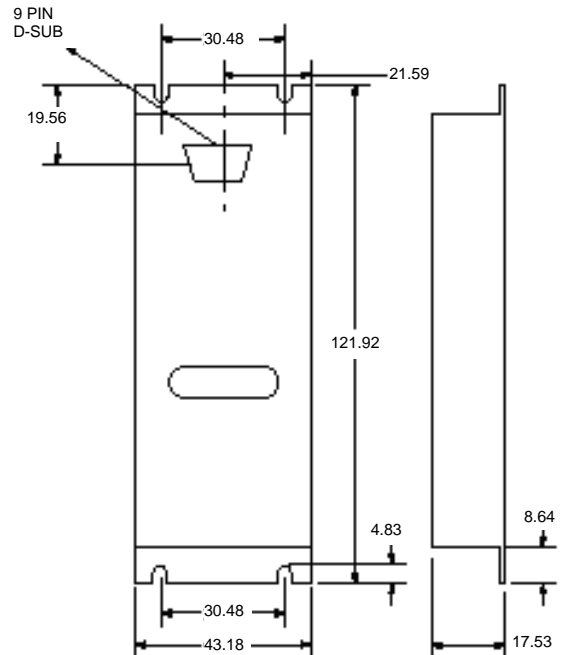
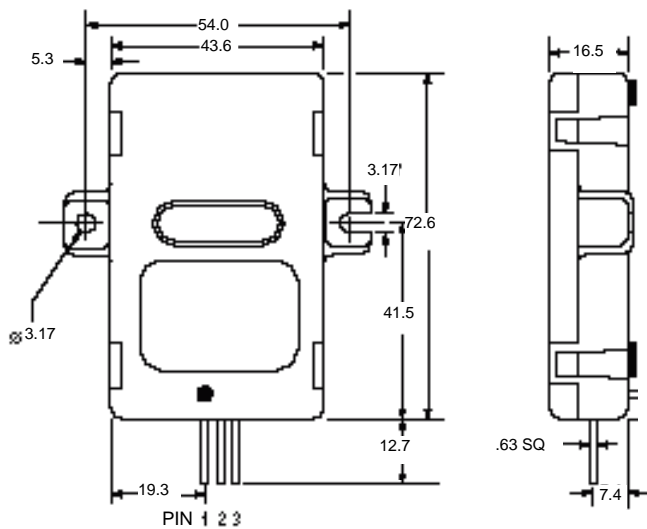

# AVS Series

## Air Velocity Sensors

### Sample Response, Non-Directional

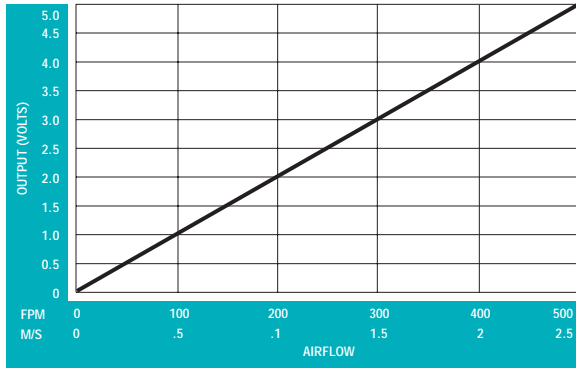

### Sample Response, Bi-Directional

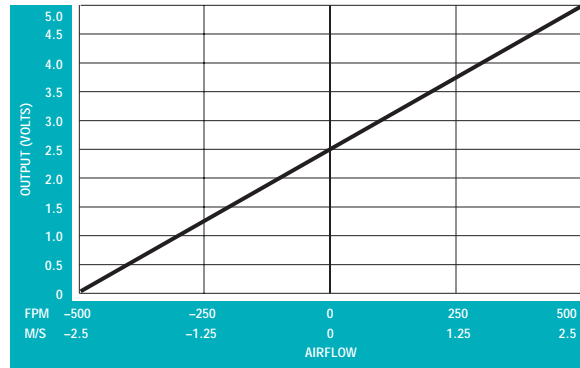

### Airflow vs. Pressure

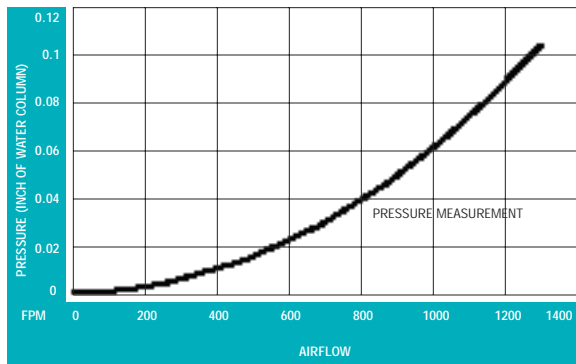

At low velocities, the equivalent pressure measurements become very small and difficult to measure accurately and economically with traditional pressure sensors.

The AVS Series gives its strongest signals at the lowest velocities, thus eliminating the inaccuracies caused by converting minute differential pressures to an airflow reading.

### Specifications

Supply	Minimum	Nominal	Maximum
12D	10	12	16 VDC
24D	18	24	30 VDC

Accuracy From 15 to 35 °C 5% of full scale, 3% of full scale at 21 °C

Accuracy Below 30 fpm	not guaranteed
Operating Temperature	-10° to 70° C
Storage Temperature	-40° to 100° C
Supply Current	50 mA nominal
Repeatability At 25° C	±1% full scale
Response Time	100 ms std., other response times avail.
Output Resolution	256 steps
Warm-up Time	10 minutes maximum
Current Loop Load	0-200 ohms
Humidity (Non-Condensing)	10% to 90% RH
Cable	Shielded Teflon (diameter 1.78 mm)

#### Connector Configuration

##### 3 Pin Header

- 1 = Supply (Vcc)
- 2 = Return (GRD)
- 3 = Output

##### DB9

- 1 = Supply (Vcc)
- 2 = Output
- 6 = Return (GRD)
- Remaining pins on DB9 connector reserved for future use

### Sensor Flow Direction

Bi-Directional—Dot facing flow is positive direction.  
Logo facing flow is negative direction.

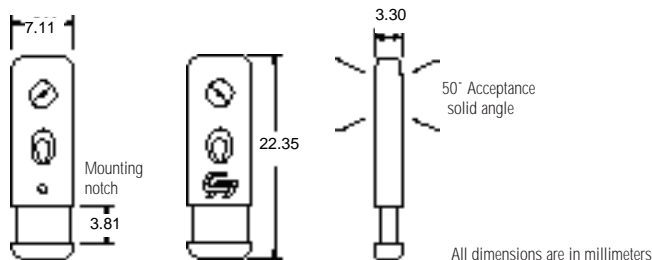

Case Material	Plastic Metal	ABS Powder coated aluminum
Weight	Plastic Metal	36 grams 80 grams

# AVS Series

## Air Velocity Sensors

### Part Numbering Scheme

AVS	XX	XXX	X	X(X)	X	X	X
AIR VELOCITY SENSOR	SERIES	SUPPLY VOLTAGE	CASE	VELOCITY RANGE (See Below)	OUTPUT	CABLE LENGTH (Shielded)	CONNECTOR OPTIONS
	10= Non-Directional Sensor 11= Bi-Directional Sensor	12D=12VDC 24D= 24VDC Metal Case Only	0= Plastic 1= Metal	D = 200 fpm F = 500 fpm H = 1000 fpm J = 0.5 m/s L = 1.0 m/s N = 2.5 m/s P = 5 m/s  Other Ranges Available, contact AccuSense	2= 0-10V 3= 4-20 mA	1= 1m 2= 2m	2 = Panel Mount 3 Pin Header (plastic case) 4 = Femal DB9 (metal case)  1 = 7478 Right Angle Friction Lock, 3 pin header (Molex p/n 22-05-3031)

#### VELOCITY RANGES

Non-Directional– Choose 1 letter for ending velocity range: e.g., B= 100 fpm. Overall velocity range is 0 to 100 fpm.

Bi-Directional - Choose 1 letter for the ending velocity which will represent both the negative and positive velocity (e.g., an AVS with the letter D has a velocity range of -200 to +200 fpm).

Accuracy on the bi-directional AVS begins from the bottom of the negative range to the top of the positive range (e.g. -200 to +200 calibration's full scale is 400 fpm).



Cambridge AccuSense, Inc.  
1000 Mt. Laurel Circle  
Shirley, MA 01464 USA

edited 9/29/99

Phone 1-800-313-9271 / 978-425-2090  
Fax 978-425-4062

Email

Sales: sales@accusense.com

Tech Support: tech@accusense.com

Please visit our www site at: <http://www.accusense.com>

## Universal Series

### Features

- Measures airflow directly
- Linear output
- Ultra-sensitive to low velocity
- Rugged
- Cost-effective
- Bi-directional option available
- Easy to use
- Choice of outputs, including
  - 0-10V, 4-20mA
- CE approved

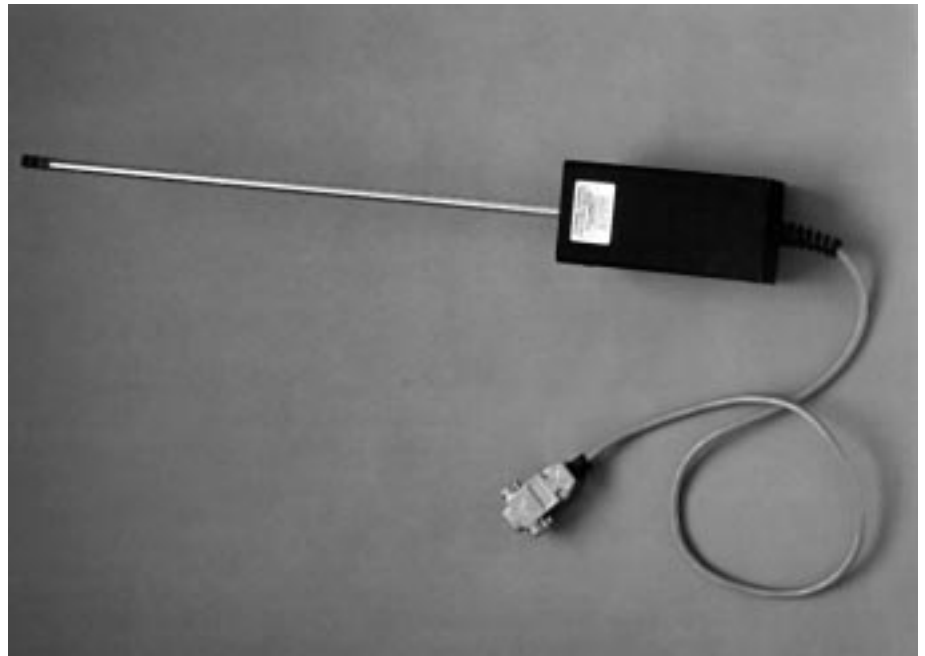

The new AVS Universal Series by Cambridge AccuSense, Inc. are thermistor-based transducers specially designed to obtain direct measurements of ultra-low air velocities, covering a range that starts as low as 0-100 fpm full scale (0-.5m/s), and reaching up to 0-1000 fpm (0-5 m/s); the output is linear with velocity.

With a standard response time of approximately 100 milliseconds, these new transducers feature accuracy of  $\pm 3\%$  of full scale at room temperature, and eliminate the need to convert differential pressure readings in order to obtain an equivalent airflow measurement.

Individually calibrated in Cambridge AccuSense's NIST traceable wind tunnels, the rugged AVS Universal

Series is also offered in a bi-directional version that provides a positive or negative reading, depending on the direction of the airflow. The large thermistor signal ensures little drift, improved stability and better sensitivity at low velocities than traditional measurement methods. The unit is powered by 12-24VDC; output choices include 0-10V or 4-20 mA.

Applications for this new technology include monitoring airflow at HEPA filters to control fans and blowers, and to monitor critical processes in cleanrooms such as mini-environments. Additional uses include measuring airflow in fumehoods, biosafety cabinets, wind tunnels, and HVAC duct work. The AVS Universal Series provides a cost-effective and efficient alternative to traditional methods.

### Specifications

Model	Minimum	Nominal	Maximum
12D	10		16 VDC
24D	12		24 VDC
Supply Current	50 mA		
Operating Temperature	-10° to 70°C		
Storage Temperature	-40° to 100°C		
Accuracy from 15° to 35°C above 30 fpm	$\pm 5\%$ of full scale $\pm 3\%$ of full scale at 21°C		
Accuracy below 30 fpm	<b>not guaranteed</b>		
Repeatability at 21°C	$\pm 1\%$ full scale		
Response Time	100 ms standard		
Output Resolution	256 steps		
Warm-Up Time	3 minutes maximum		
Current Loop Load	0-200 ohms		
Humidity (non-condensing)	10% to 90% RH		
Cable	Shielded cable; 24 inches long		
DB9 Connector Configuration	1 = Supply 2 = Output 6 = Return (grd)		
Case	Black Anodized Aluminum		
Weight	1 lb. maximum		

# AVS Series

## Air Velocity Sensors

### Universal Series

#### Part Numbering Scheme

AVS	XX	XXX	X	X	X	X	X
AIR VELOCITY SENSOR	SERIES	SUPPLY VOLTAGE	CASE	VELOCITY RANGE (See Below)	OUTPUT	WAND	CONNECTOR OPTIONS
	10 = Non-Directional Sensor 11 = Bi-Directional Sensor	12D = 10-16 VDC 24D = 12-24 VDC	2 = Universal Package	B = 100 fpm D = 200 fpm F = 500 fpm H = 1000 fpm J = 0.5 m/s L = 1.0 m/s N = 2.5 m/s P = 5 m/s Custom Ranges Available	2 = 0-10V 3 = 4-20 mA	0 (12.5 inch stainless steel rod)	4 = Female DB9

#### VELOCITY RANGES

**Non-Directional** – Choose 1 letter for ending velocity range: e.g., B= 100 fpm. Overall velocity range is 0 to 100 fpm.

**Bi-Directional** – Choose 1 letter for the ending velocity, which will represent both the negative and positive velocity (e.g., an AVS with the letter D has a velocity range of -200 to +200 fpm).

Accuracy on the bi-directional AVS begins from the bottom of the negative range to the top of the positive range (e.g. -200 to +200 calibration's full scale is 400 fpm).



Cambridge AccuSense, Inc.  
1000 Mt. Laurel Circle  
Shirley, MA 01464 USA

Phone 1-800-313-9271 / 978-425-2090  
Fax 978-425-4062

Email  
Sales: sales@accusense.com  
Tech Support: tech@accusense.com  
Please visit our www site at: <http://www.accusense.com>