

# Series 300

## Airflow Switches

### Features

- All solid-state technology
- No need for user calibration
- Ideal for monitoring low flows
- Performance is not affected by dirt and vibration
- Hysteresis-free
- Cost effective
- Processing electronics are not required
- Available in uni-directional or bi-directional versions
- Choice of standard or customized calibrations

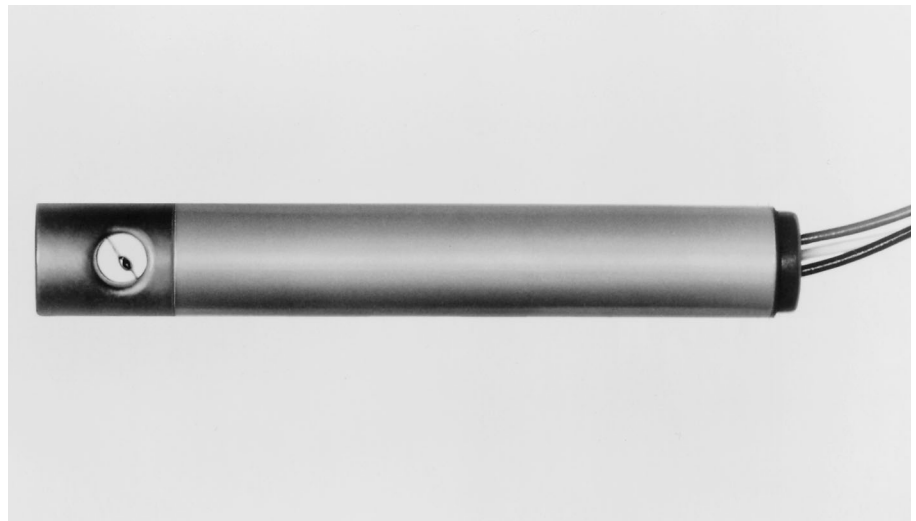

The Cambridge AccuSense Series 300 is a line of solid-state, highly reliable electronic switches, designed to monitor airflow in critical environments such as cleanrooms, semiconductor fabrication facilities, and operating rooms as well as in traditional electronic enclosures to warn of cooling degradation. These compact, easy-to-install units detect loss of airflow below a pre-programmed set-point, and provide an effective, fast and distinct warning of airflow deterioration.

Designed to replace traditional "sail" or "vane" switches, the Series 300 switches offer unparalleled resistance to mechanical shock and vibration. The Series 300 sensor head may be either uni-directional\* or bi-directional. The uni-directional

model discriminates between forward and reversed airflow, indicating a fault if the airflow direction reverses. The bi-directional model accepts airflows from either of two opposing directions.

The output of the Series 300 can be used to drive computer logic or it can activate alarms, relays, or other circuits. Normally-open (N.O.) and Normally-closed (N.C.) versions are available.

### Comparison of Alternative Methods for Sensing Airflow Failure

	Fan Speed <sup>1</sup> (Hall Effect)	Temp. <sup>2</sup> Sensor	Mechanical <sup>3</sup> Vane Switch	Airflow Switch
Response to:				
Fan failure	Fast	Slow	Medium	Fast
Blocked inlet filters	None	Slow	Poor	Fast
Wrong fan rotation	None	Slow	Medium	Fast
Reliability	High	Medium	Low	High
Processing electronics required	Yes	Maybe	No	No
Applicability for low speed airflow	N/A	N/A	None	Good
Multiple fan sourcing	Difficult	Yes	Yes	Yes

- <sup>1</sup> The Hall effect sensor measures fan blade rotation only, and cannot respond to airflow deteriorations caused by blockage.
- <sup>2</sup> Problem indication provided by a temperature sensor may be significantly delayed after the airflow is interrupted, and may actually not occur at all, depending on the equipment convection patterns.
- <sup>3</sup> The mechanical vane switch is position-sensitive, easily affected by dirt and vibration, and since it has moving parts, its performance tends to be less reliable.

## Typical Installations

Applications for the Series 300 Airflow Switches include computer systems and peripherals, electronic equipment, process control, cleanrooms and air conditioning and ventilation systems.

Some typical locations are:

- Upstream or downstream of cardcages, power supplies and filters.
- In a plenum of air cooling intake.
- In an inlet or in an exhaust flue.

The Series 300 Switches may be located in areas where the airflow velocity is above 0.25 m/s (50 fpm), with the sensing element facing the airflow within a 20° solid angle.

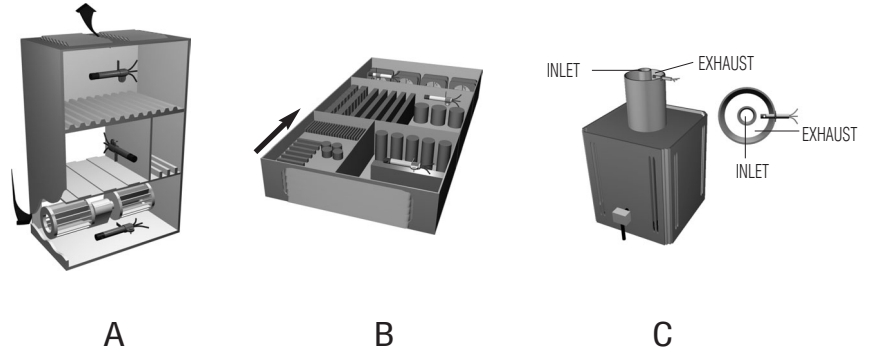

## Customized Wire Links and Terminations

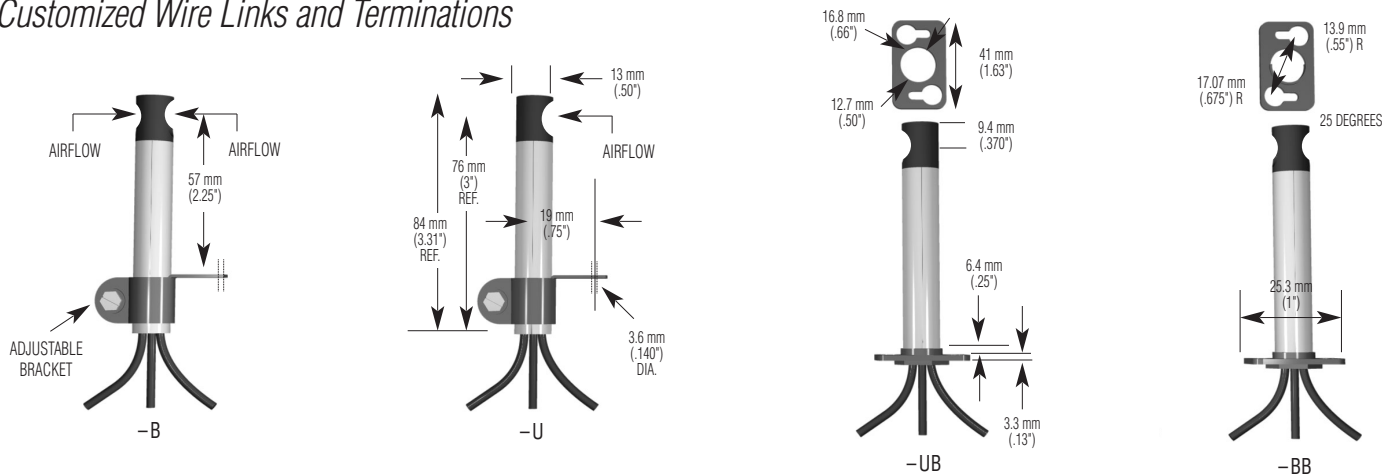

## Electrical Arrangements

### (1) To Drive Logic

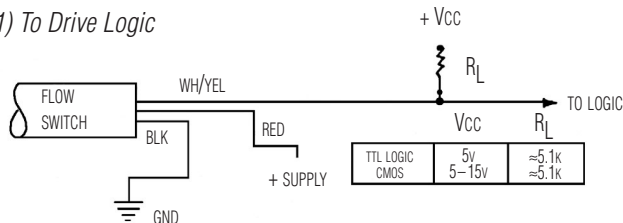

### (2) To Drive Circuit-Breakers, Relays, Alarms

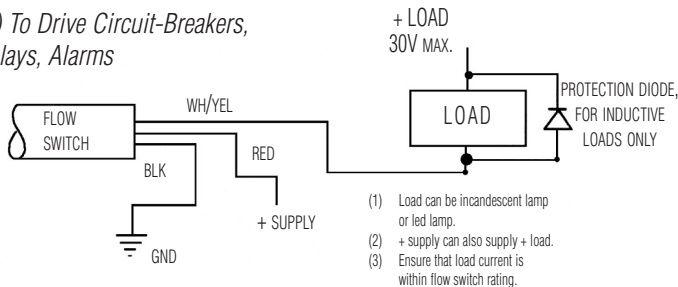

### (1) To Drive Warning Lamp or LED Indicator

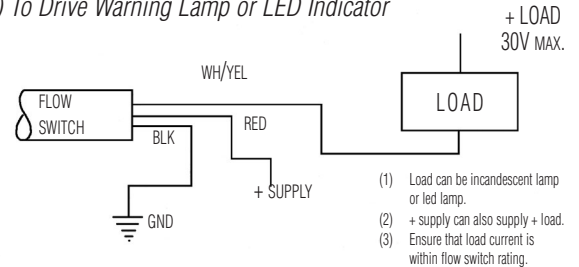

### (4) Multiple Flow Switches

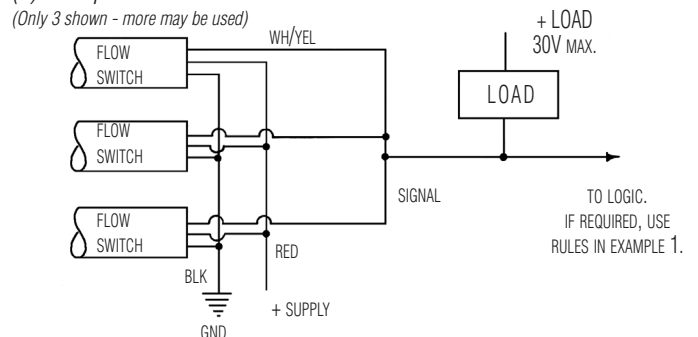

# Series 300

## Airflow Switches

### Standard Calibration Curves

The Series 300 switch measures the airflow cooling capacity by sensing an air sample. Cooling capacity is a function of air velocity, temperature, density, and specific heat. At higher ambient temperature, the device calls for a larger volume of cooling air. The relationship of air temperature and airflow velocity is defined by the calibration curve of the switch. If the velocity and temperature of a given installation do not come up to the preset threshold, the device will trip abruptly from No-Fault to Fault, or vice versa, along a clear-cut single line without hysteresis. At the fault/no-fault line, the Series 300 trips an open collector output transistor. The output of the transistor may be used to drive logic, LED, relays, and other alarm or shut-off devices.

The dotted lines in the calibration curve figures indicate the device-to-device tolerance limits (trip windows) from the calibrated curve.

Because the air is thinner at higher altitudes, the Series 300 will automatically compensate by calling for higher air velocities to achieve the same cooling effect. (See Correction for Altitude Chart.)

Custom curves are available.

The D Series is a new set of calibrations designed specifically for low airflow monitoring below 200 fpm (1 m/s). The temperature range for the D Series is 17 - 25 °C. Accuracy is ±10 fpm.

Curve	Trip Point
D1	50 fpm (.25 m/s)
D2	60 fpm (.3 m/s)
D3	80 fpm (.4 m/s)
D4	100 fpm (.5 m/s)
D5	120 fpm (.6 m/s)
D6	150 fpm (.75 m/s)
D7	180 fpm (.9 m/s)
D8	200 fpm (1 m/s)

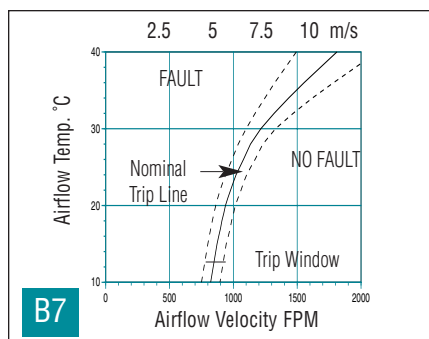
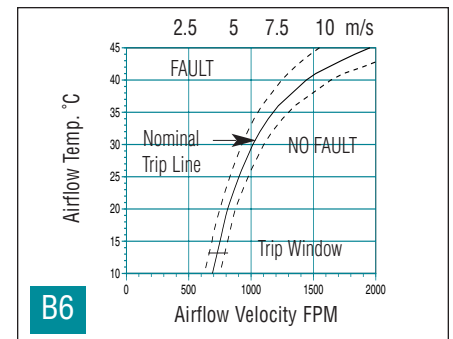
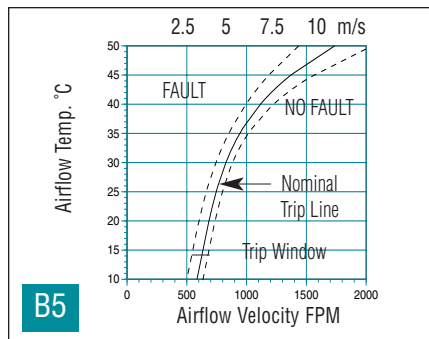
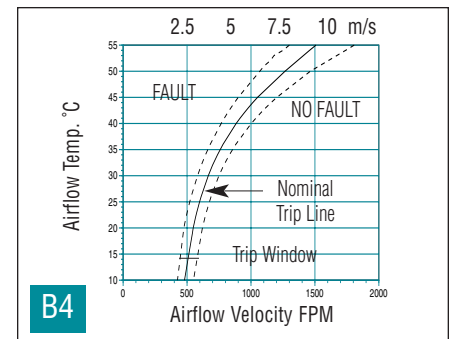
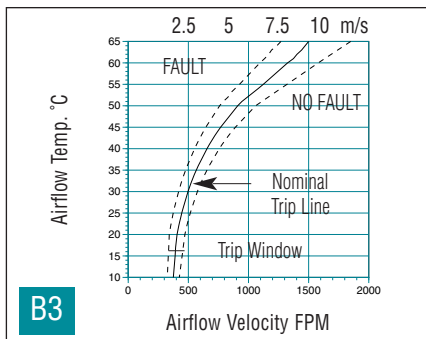
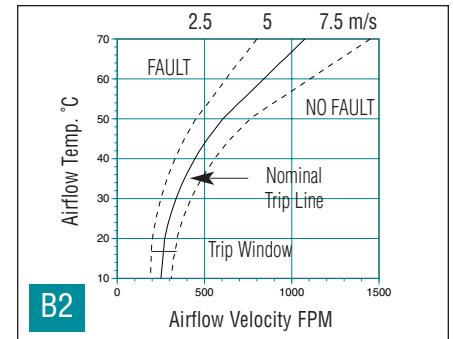
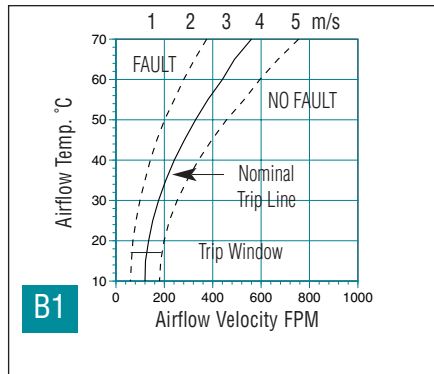

### Correction for Altitude

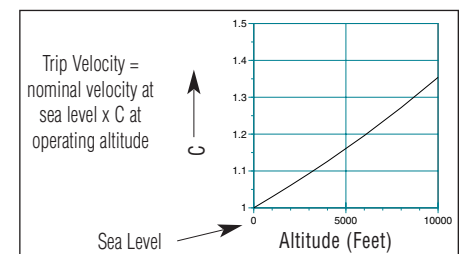

# Series 300

## Airflow Switches

### Specifications

	Minimum	Nominal	Maximum	
Supply Voltage (305)	4.5	5	5.5	V
Supply Voltage (300T)	11		25	V
Power Dissipation	.2	.6	.8	W
Input Current (305)	100		140	mA
Input Current (300T)	2		60	mA
Output Signal*	3		30	V
Output, High: Leakage Current			1	µA
Output, Low:			1	V
Output, Low: Max Sink Current			110	mA
Operating Temp	5		60	°C
Humidity, Non-Condensing	10		95	RH(%)
Response Time for Fault Signal			3 Sec Above 15°C 30 Sec Below 15°C	
Start-up Time from Power Up under Fault Condition			3 Sec Above 15°C 30 Sec Below 15°C	
Storage Temperature	-10		80	°C

\* Open collector of an NPN Transistor; Emitter to return VDC; Pull up voltage.

### Part Numbering Scheme

30XX	X	X	X
SERIES	CONNECTOR OPTIONS	OUTPUT	CURVE
305 = 305 Series (5V version)	B = Bi-Directional/ Bracket Mount	O = Normally Open, N.O.	Any applicable curve from standard curve charts
300T = 300T Series	U = Uni-Directional/ Bracket Mount	N = Normally Closed, N.C.	
	BB = Bi-Directional/ Base Mount		
	UB = Uni-Directional/ Base Mount		

Normally open = circuit is open above trip point

Normally closed = circuit is closed above trip point



**CAMBRIDGE ACCUSENSE, INC.**

Cambridge AccuSense, Inc.  
1000 Mt. Laurel Circle  
Shirley, MA 01464 USA

Phone 1-800-313-9271 / 978-425-2090  
Fax 978-425-4062

Email  
Sales: sales@accusense.com  
Tech Support: tech@accusense.com  
Please visit our www site at: <http://www.accusense.com>